

**MODEL PAPI
PRE-INSULATED ANCHOR**

ANCHOR HARDWARE

AVAILABLE MATERIALS: CARBON STEEL OR STAINLESS STEEL
POWDER-COATED FINISH (CARBON STEEL ONLY 2 MIL)

INSULATION INSERT

360° ASBESTOS-FREE XONOLITE CALCIUM SILICATE -
900 PSI COMPRESSIVE STRENGTH (10" AND 12" - 1600 PSI)
K-FACTOR: .66 @ 400°F (10" AND 12" - .70 @ 400°F)
MEETS ASTM C-533, C-585, C-795, E-72, AND E-84.
FLAME SPREAD -0-, SMOKE DEVELOPED -0-
ALL UNITS INCLUDE A VAPOR BARRIER JACKET MEETING ASTM D-744
AND PROTECTION SHIELD OF GALVANIZED OR STAINLESS STEEL

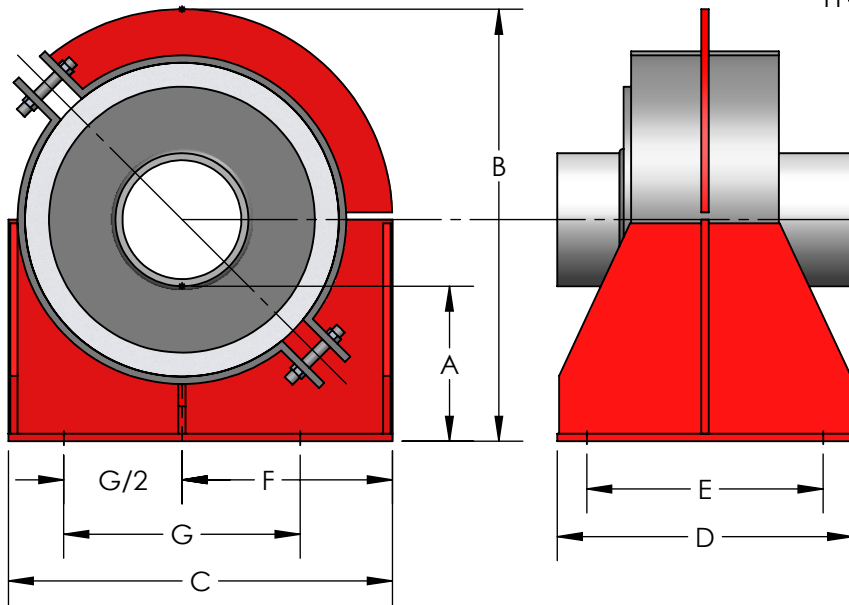
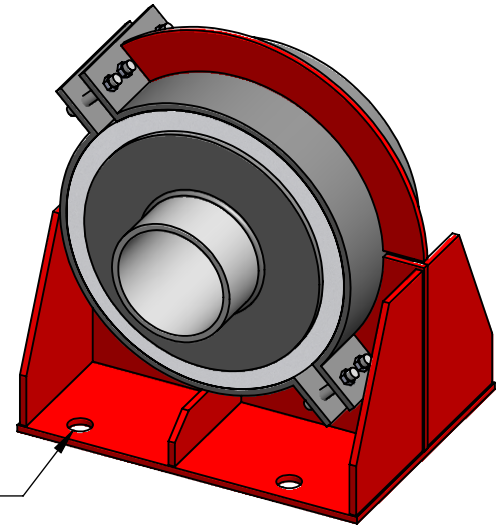

COMPLETELY ASSEMBLED. READY TO BE
WELDED TO PIPE AND BOLTED OR
WELDED TO STRUCTURE.

HIGH ANCHOR LOADS. NO METAL TO
METAL CONTACT. PRE-INSULATED
ANCHORS DELIVER MAXIMUM
INSULATION EFFECTIVENESS AND
ENERGY SAVINGS. UNIQUE DESIGN AND
HIGH COMPRESSIVE STRENGTH
INSULATION ALLOWS THIS ANCHOR TO
SUPPORT WORKING LOADS UP TO
30,500 LBS AND TEST LOADS OF UP
TO 45,750 LBS.

MAXIMUM WORKING TEMPERATURE: 1200°F

QTY	PART NUMBER	PIPE SIZE	ANCHOR DIMENSIONS								WORKING LOADS	INSULATION THICKNESS
			A	B	C	D	E	F	G	H		
	PAPI0150	1-1/2"	5.56"	12.13"	10.00"	8.00"	6.00"	5.63"	5.00"	0.63"	2,200 LBS	2"
	PAPI0200	2"	5.31"	12.13"	10.00"	8.00"	6.00"	5.63"	5.00"	0.63"	2,200 LBS	2"
	PAPI0250	2-1/2"	5.63"	13.68"	12.00"	8.00"	6.00"	6.63"	7.00"	0.63"	5,750 LBS	2-1/2"
	PAPI0300	3"	5.31"	13.68"	12.00"	8.00"	6.00"	6.63"	7.00"	0.63"	5,750 LBS	2-1/2"
	PAPI0400	4"	5.31"	14.63"	12.75"	10.00"	8.00"	7.06"	8.00"	0.88"	7,150 LBS	2-1/2"
	PAPI0500	5"	5.31"	15.75"	14.00"	10.00"	8.00"	7.69"	9.00"	0.88"	9,100 LBS	2-1/2"
	PAPI0600	6"	5.38"	17.38"	16.00"	12.00"	10.00"	8.69"	11.00"	0.88"	12,800 LBS	3"
	PAPI0800	8"	6.81"	21"	18.75"	12.00"	10.00"	10.06"	13.00"	1.13"	17,500 LBS	3"
	PAPI1000	10"	7.00"	24.38"	22.50"	20.00"	16.00"	12.00"	15.00"	1.63"	24,500 LBS	3"
	PAPI1200	12"	7.19"	26.50"	24.50"	22.00"	18.00"	12.94"	17.00"	1.63"	30,500 LBS	3"

NSF 372 - LEAD FREE

The wetted surface of this product contacted by consumable water contains less than one quarter of one percent (0.25%) of lead by weight. Material complies with state codes and standards, where applicable, requiring reduced lead content.

CUSTOMER: _____

PROJECT: _____

ENGINEER: _____

REV.	DATE
2323 W. HUBBARD ST. CHICAGO, IL 60612 TEL: 312-738-3800 FAX: 312-738-0415 WWW.METRAFLEX.COM	
MODEL PAPI PRE-INSULATED ANCHOR	
DRAWN BY: DKISH	DATE: 3/15/2019
APPROVED:	DATE:
SCALE: N/A	DRAWING NUMBER: PAPI-2