

# MODEL VFR

## VANEFLEX WITH 150# PLATE FLANGES AND CONCENTRIC REDUCER

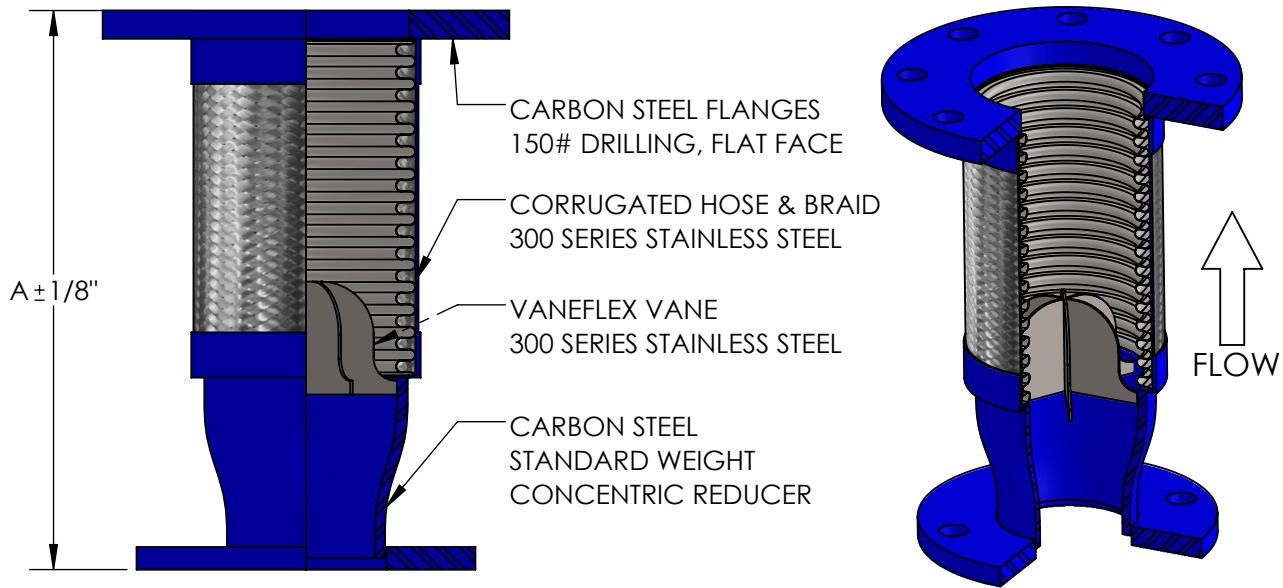

QTY	PART NUMBER	PIPE SIZE		A	PRESSURE RATING (PSI)*	WEIGHT (LBS)	PROJECT INFORMATION
		SMALLER	LARGER				
	VFR0225	2"	2-1/2"	12-1/4"	387	17	
	VFR0203	2"	3"	12-1/4"	316	18	
	VFR2503	2-1/2"	3"	12-1/4"	316	19	
	VFR0204	2"	4"	12-3/4"	232	24	
	VFR2504	2-1/2"	4"	12-3/4"	232	24	
	VFR0304	3"	4"	12-3/4"	232	25	
	VFR2505	2-1/2"	5"	15-3/4"	191	33	
	VFR0305	3"	5"	15-3/4"	191	33	
	VFR0405	4"	5"	15-3/4"	191	34	
	VFR0306	3"	6"	16-1/4"	165	39	
	VFR0406	4"	6"	16-1/4"	165	39	
	VFR0506	5"	6"	16-1/4"	165	40	
	VFR0408	4"	8"	17-1/2"	234	67	
	VFR0508	5"	8"	17-1/2"	234	68	
	VFR0608	6"	8"	17-1/2"	234	68	
	VFR0610	6"	10"	19-1/2"	230	100	
	VFR0810	8"	10"	19-1/2"	230	102	
	VFR1012	10"	12"	21-1/2"	161	142	

\*FOR SAFE WORKING PRESSURE ABOVE 70°F, MULTIPLY THE PRESSURE SHOWN AT 70°F TIMES THE CORRECTION FACTOR OF THE REQUIRED TEMPERATURE.

TEMPERATURE (°F)	FACTOR
70	1.0
200	.91
300	.85
400	.78
500	.77
600	.76

MAX INTERMITTENT OFFSET FROM CENTERLINE 1/8"  
MAX PERMANENT OFFSET FROM CENTERLINE 3/8"

### NSF 372 - LEAD FREE

The wetted surface of this product contacted by consumable water contains less than one quarter of one percent (0.25%) of lead by weight. Material complies with state codes and standards, where applicable, requiring reduced lead content.

REV.	1	TEMP FACTOR UPDATED	DATE 1/4/2017
		2323 W. HUBBARD ST. CHICAGO, IL 60612 TEL: 312-738-3800 FAX: 312-738-0415 WWW.METRAFLEX.COM	

CUSTOMER: \_\_\_\_\_

PROJECT: \_\_\_\_\_

ENGINEER: \_\_\_\_\_

### MODEL VFR

VF, 150# PLATE FLANGES, CONCENTRIC REDUCER

DRAWN BY: <b>DKISH</b>	DATE: <b>11/22/2013</b>
APPROVED: <b>JC</b>	DATE: <b>11/22/2013</b>
SCALE: N/A	DRAWING NUMBER: VFR-1