

**MODEL SSTC
THREADED FLEXIBLE PUMP CONNECTOR**

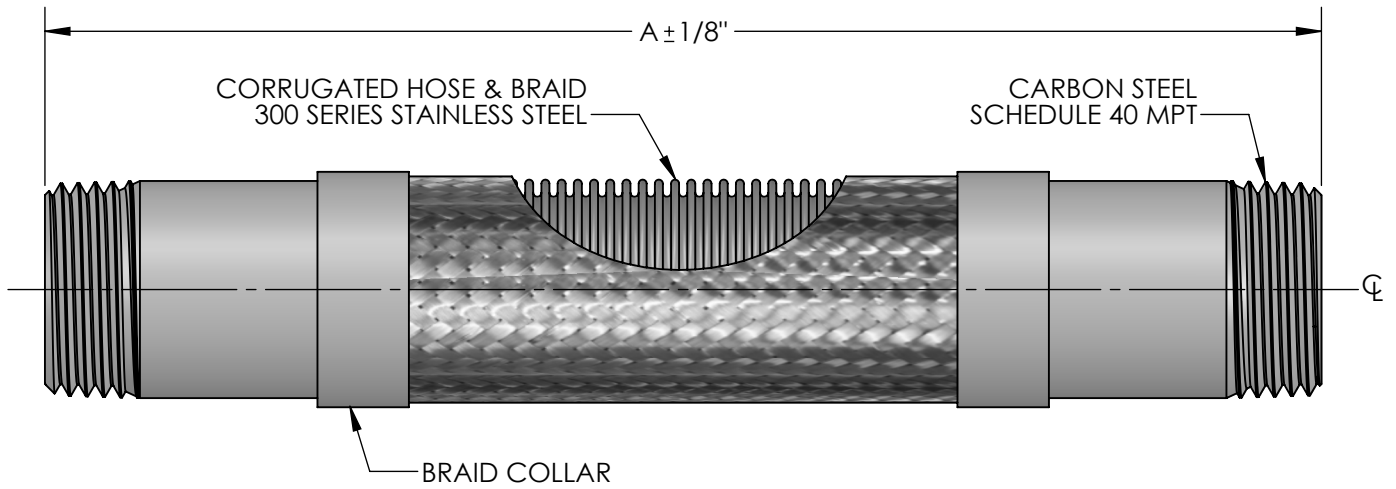

NOTE: DO NOT USE WRENCHES ON HOSE OR BRAID COLLAR.

QTY	PART NUMBER	PIPE SIZE		A	PRESSURE RATING (PSI)*	WEIGHT (LBS)	PROJECT INFORMATION
		INCH	MM				
	SSTC0050	1/2"	15	10"	1075	0.5	
	SSTC0075	3/4"	20	10"	792	0.8	
	SSTC0100	1"	25	10"	571	1	
	SSTC0125	1-1/4"	32	10"	531	1.5	
	SSTC0150	1-1/2"	38	12"	472	2	
	SSTC0200	2"	50	14"	516	3	
	SSTC0250	2-1/2"	65	16"	387	4	
	SSTC0300	3"	80	16"	316	6	

*FOR SAFE WORKING PRESSURE ABOVE 70°F, MULTIPLY THE PRESSURE SHOWN AT 70°F TIMES THE CORRECTION FACTOR OF THE REQUIRED TEMPERATURE.

MAX INTERMITTENT OFFSET FROM CENTERLINE 1/4"
MAX PERMANENT OFFSET FROM CENTERLINE 1/2"

TEMPERATURE (°F)	FACTOR
70	1.0
200	.91
300	.85
400	.78
500	.77
600	.76

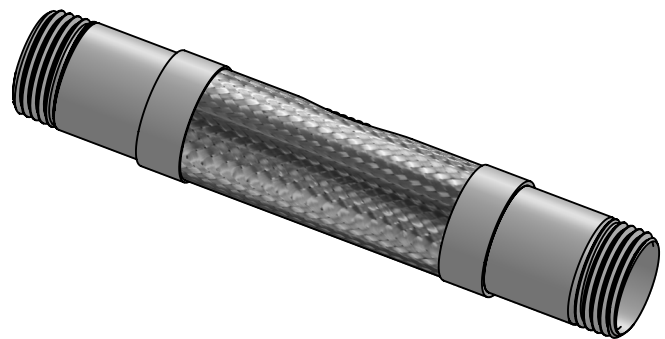

NSF 372 - LEAD FREE

The wetted surface of this product contacted by consumable water contains less than one quarter of one percent (0.25%) of lead by weight. Material complies with state codes and standards, where applicable, requiring reduced lead content.

CUSTOMER: _____

PROJECT: _____

ENGINEER: _____

REV.	1	TEMP FACTOR UPDATED	DATE 12/28/2016
		2323 W. HUBBARD ST. CHICAGO, IL 60612 TEL: 312-738-3800 FAX: 312-738-0415 WWW.METRAFLEX.COM	
		MODEL SSTC THREADED FLEXIBLE PUMP CONNECTOR	
DRAWN BY: DKISH		DATE: 1/10/2014	
APPROVED: JC		DATE: 1/10/2014	
SCALE: N/A		DRAWING NUMBER: SSTC-1	