

316 Stainless Steel Plate
Slip-On Flange
150# Drilling

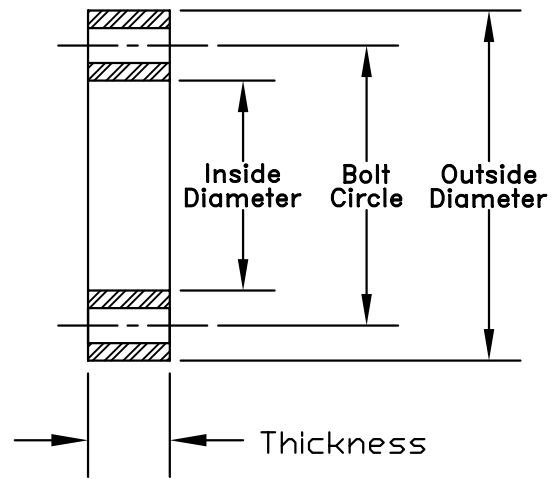
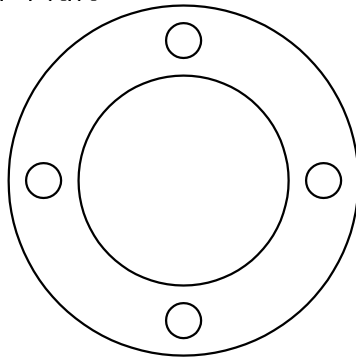

Notes:

1. All surfaces to be machined (ID, OD, and both flange faces) and coated with a rust prohibitive.
2. Unless otherwise specified, the manufacturer may supply either spiral or concentric grooves for serrations on both flange faces. The spiral machining operation is commonly accomplished with the cutting tool having 0.06 in (1.6 mm) or larger tip radius. Finish on flange faces is to conform to MSS SP-6 Standard.

SIZE	THICK.	I.D.	O.D.	B.C.	BOLT HOLES		WEIGHT
					NO.	DIA.	LBS.
1	1/2	1.36	4-1/4	3-1/8	4	5/8	1.7
1-1/4	1/2	1.70	4-5/8	3-1/2	4	5/8	2.0
1-1/2	1/2	1.95	5	3-7/8	4	5/8	2.3
2	1/2	2.44	6	4-3/4	4	3/4	3.2
2-1/2	1/2	2.94	7	5-1/2	4	3/4	4.4
3	1/2	3.57	7-1/2	6	4	3/4	4.9
4	1/2	4.57	9	7-1/2	8	3/4	6.6
5	1/2	5.66	10	8-1/2	8	7/8	7.3
6	1/2	6.72	11	9-1/2	8	7/8	8.2
8	3/4	8.72	13-1/2	11-3/4	8	7/8	17.5
10	3/4	10.88	16	14-1/4	12	1	21.9
12	3/4	12.88	19	17	12	1	32.1

ALL DIMENSIONS ARE IN INCHES

CUSTOMER _____

PROJECT _____

ENGINEER _____

ARCHITECT _____

INQ. OR P.O. NO. _____



2323 W. HUBBARD ST.
CHICAGO, IL 60612
TEL:312-738-3800
FAX:312-738-0415
WWW.METRAFLEX.COM

DESCRIPTION: 316 Stainless Steel Plate
Slip-On Flange 150# Drilling

DRAWN BY: SR

DATE: 08/18/06

APPROVED BY:

DATE:

BREAK SHARP CORNERS AND REMOVE BURRS

SCALE:
NONE

TOLERANCE UNLESS
SPECIFIED

DRAWING NUMBER:

150-FLG-SS-316

REV.

01